



# MIB 303

## Solids-retaining Centrifugal Separator

### Application

The MIB 303 separation system is designed for centrifugal separation of sludge and water from mineral oil.

The separator is designed for oils with a maximum density of 920 kg/m<sup>3</sup> at 15°C. The maximum separation temperature for gas oil and marine diesel oil is +40°C, and for lubricating oil +70°C, since this is the max. separation temperature for the separator.

### Mineral Oil

The MIB 303 separator in a cleaning system for distillate and marine diesel oil should be operated as a purifier. For cleaning of lubricating oil, MIB 303 purifier or clarifier can be used.

### Concept

The MIB 303 separator features a new design concept for solid-bowl separators. Advanced manufacturing, design and drive technologies have contributed to a separator more compact and lightweight than conventional solid-bowl models.

### Features

- No lock ring. Requires only small mechanical force on opening/assembling of the bowl.
- New design allows the bowl wall to be taken out and cleaned with the disc stack still in place.
- New lightweight materials in bowl and discs.
- Direct drive with motor speed controlled by a frequency converter eliminates gears or belts.
- Requires no lubrication.
- The cleaned oil is discharged under pressure, due to the built-in paring disc pump.
- Frequency converter with built-in voltage protector.



### Benefits

- Easy to install, operate and maintain. No special training required.
- Small dimensions allow installation in narrow spaces.
- Removal of solid impurities extends intervals between filter replacements, which saves filter costs and reduces filter disposal handling.
- Removal of water from mineral oil improves the reliability of the oil system. It also reduces the risk of bacterial growth in tanks that could clog the filters.
- Electronics protected from voltage variations.

### Throughput capacity

The MIB 303 separator has a throughput capacity of max. 760 litres per hour of diesel/gas oil and max. 460 litres per hour of steam turbine lube oil.

### Standard equipment

Separator with drive, funnel for water supply with connections.

### Ancillary equipment

Necessary for operation are: Starter for separator, feed pump with starter, collecting tank with water seal alarm, strainer, valves and fittings.

### Available models

The MIB 303 separator is available as a purifier or a clarifier in stand-alone and module versions.

There is also a choice between 230 V AC, 110 V AC and 24 V DC.

In the module version the ancillary equipment mentioned above is built together with the separator to form a compact unit.

### Power consumption

700 W  $\pm$ 10%.

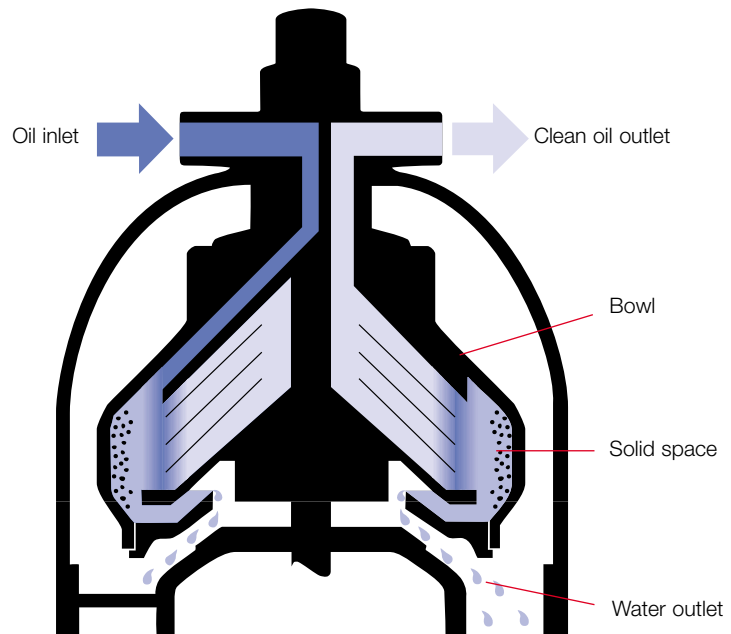

Functional principle of the MIB 303 purifier.

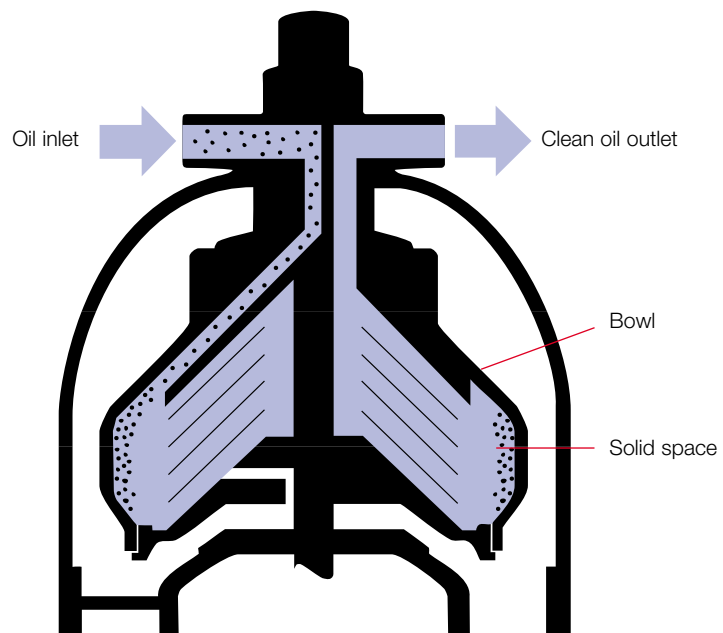

Functional principle of the MIB 303 clarifier.

### Purifier operation

Separation takes place in the rotating solid-wall bowl. The uncleaned oil is fed into the bowl where the centrifugal force makes water and solid particles move out towards the periphery of the bowl, while the clean oil flows inwards.

To establish a water seal during start-up of the separator, water is added to the bowl before the oil feed is started. The water collects in the water seal which drains into the water channel below the bowl.

The solids accumulate on the bowl wall and are removed periodically by hand.

The cleaned oil flows towards the centre of the bowl and up to the paring disc. Since the oil is rotating, the stationary paring disc acts as a pump which forces the oil out through the outlet under pressure.

### Clarifier operation

In clarifier mode the oil normally does not contain any free water. The separation principle is similar to that of the purifier, although there is no water seal and no water outlet in the bowl and the water handling capacity is limited.

### Technical documentation

Complete information and documentation is provided in the Instruction Book accompanying each MIB 303 separator.

### After Sales support

Replacement part kits for preventive maintenance at one and two years intervals are available.



### Offered by:

Maruti Kendale

**MARS TECH**

DIV. OF KENDALE AND CO., INC.

Fluid Purification Equipment

216 Strawtown Road

New City, NY 10956

Tel: 845-638-3100 Fax: 845-638-6688

Toll Free: 800-310-5741

Web: [www.marstechusa.com](http://www.marstechusa.com)

E-mail: [sales@marstechusa.com](mailto:sales@marstechusa.com)

### Dimensions, mm

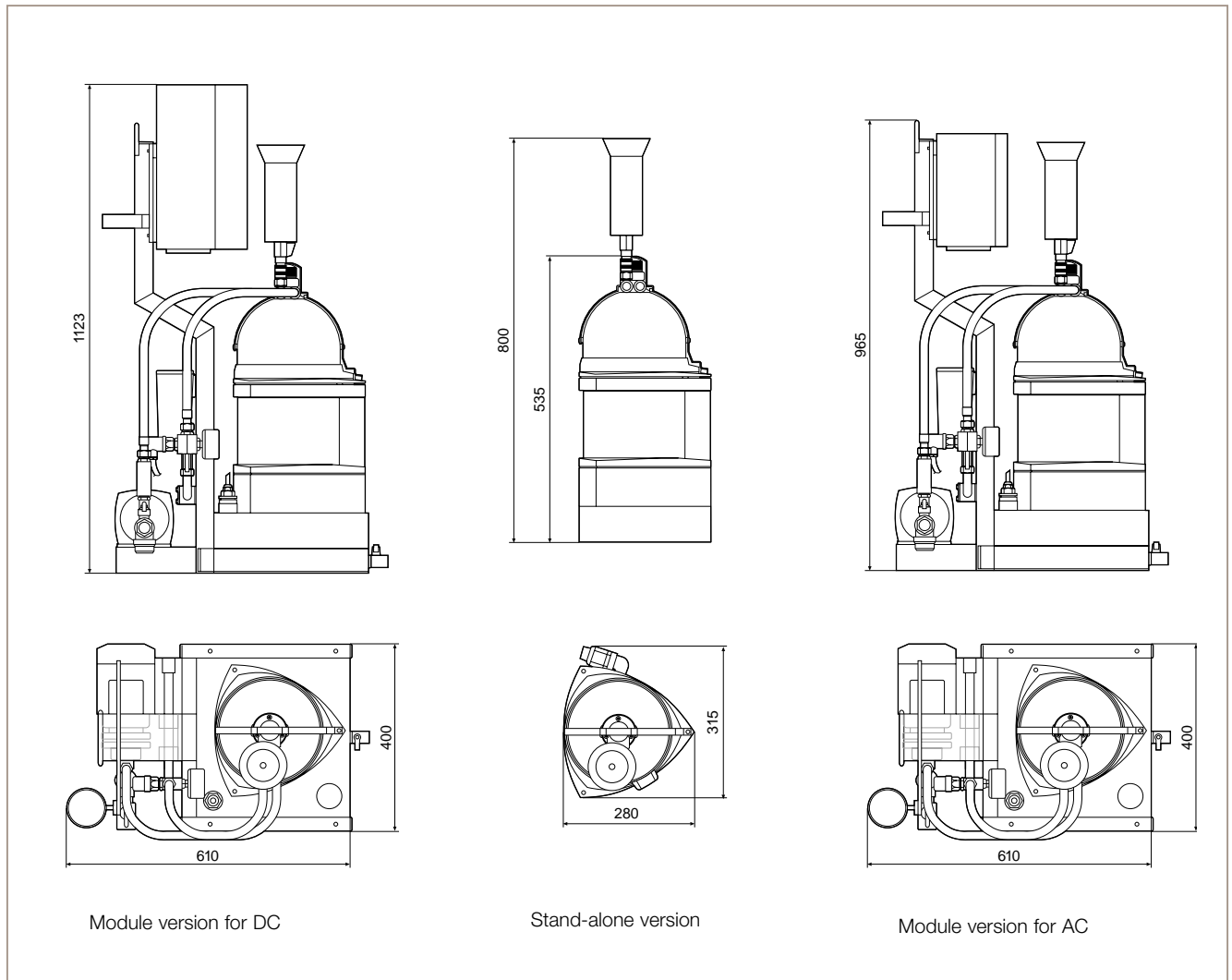



**Offered by:**

Maruti Kendale

**MARS TECH**

DIV. OF KENDALE AND CO., INC.

**Fluid Purification Equipment**

216 Strawtown Road

New City, NY 10956

Tel: 845-638-3100 Fax: 845-638-6688

Toll Free: 800-310-5741

Web: [www.marstechusa.com](http://www.marstechusa.com)

E-mail: [sales@marstechusa.com](mailto:sales@marstechusa.com)

---

**How to contact Alfa Laval**

Contact details for all countries  
are continually updated on our website.  
Please visit [www.alfalaval.com](http://www.alfalaval.com) to  
access the information direct.