



AFPX 617

High capacity solids-ejecting centrifuge for the animal and fish processing industries

Alfa Laval AFPX separator centrifuges were specially designed for extremely demanding separation jobs. Key features of the AFPX 617 centrifuge are its ability to handle high flow rates, high solids content and high-temperature processing. These functions make it the ideal choice to handle the tough conditions encountered in the animal and fish processing industries. In addition, the AFPX 617 centrifuge combines a high G-force, high sludge capabilities and automated operation. The centrifuge bowl is made of Super Duplex stainless steel, which makes it possible to combine extremely high erosion resistance with a very high bowl speed for demanding separation duties.

Applications

The AFPX 617 is designed for intermittent discharge of solids, while separating two intermixed and mutually insoluble liquid phases of different densities. In different optimized executions it is used for a large number of duties, from handling separation of fish press liquid, stick water and extracts, and on the other hand purification of fish oil and liver oil, animals fats, peel oil and similar products.

Performance

The actual throughputs depend on variables such as the amount and type of solids, the temperature, viscosity and degree of separation required. The following figures indicate the rate of performance, although no guarantees are given. Alfa Laval representatives will be pleased to provide you with further information.

Separation of fish press water	28.000 - 40.000 l/h
Purification of fish oil	18.000 - 23.000 l/h
Purification of animal fat	7.000 - 10.000 l/h

Standard design

The machine consists of a frame that has a horizontal drive shaft with clutch and brake, worm gear, lubricating oil bath and vertical bowl spindle in the lower part. The bowl is mounted on top of the spindle, inside the space formed by the upper part of the frame, the ring solids cover, the collecting cover, and the frame hood. The feed and liquid discharge system, including the paring disc pump for the heavy phase, also rests on this structure. All parts in contact with the process liquid are made of stainless steel. The bowl is of the solids-ejecting disc type with a hydraulic operating system for "shooting" (for automatic or manual operation). The electric motor is of the variable frequency drive type or of controlled-torque type.



Fig. 1 AFPX 617 complete with motor

Basic equipment

Concentrator or purifier parts, inlet and outlet devices, revolution counter, set of erosion-protective parts, illuminated sight glass box for light phase outlet, vibration switch, vibration-isolating base plate, flange motor, set of tools and standard set of spares.

Optional extras

Starter equipment, frequency converter, discharge control panel, standard set of fittings, set of CIP valves and fittings, and serviceability package for online viewing of separator status.

Material data

Bowl body, hood and lock ring	s.s. 1.4501 UNS S32760
Solids cover and frame hood	s.s. 1.4401 UNS 31600
Frame bottom part	Cast grey iron, clad with s.s. 1.4301 UNS 30400
In and outlet parts	s.s. mostly 1.4401 UNS 31600
Gaskets and O-rings	Nitrile rubber

Operating principles

Separation takes place inside a rotating bowl. The feed is introduced to the rotating centrifuge bowl (see figure 2) from the top via a stationary inlet pipe (1), and is accelerated in the distributor (2), which was specially designed to ensure smooth acceleration of the feed liquid (4). Leaving the distributor, the feed enters the disc stack (3). The separation into liquid–liquid–solids takes place between the discs, with the oil phase moving through the disc stack to the centre. When it reaches the centre, it is discharged through holes (5) and ejected into the collecting frame. The water and heavy solids separated from the oil move to the periphery, and the water flows via channels in the top disc (6) to the paring chamber, where it is pumped out of the rotor by means of a built-in paring disc (7). During purification, hot water is fed into the inlet of the bowl before the process liquid is introduced. This water forms a seal around the outer edge of the top disc. The solids collect in the periphery, where they are discharged intermittently via the centrifuge cyclone. The solids are discharged by means of a hydraulic system, which forces the sliding bowl bottom (8) to drop down at preset suitable intervals, thus opening the solids ports at the bowl periphery.

Basic executions

Purifier AFPX 617XGV-14. Purifies the light liquid phase, which is the major part of the feed mixture.

Concentrator AFPX 617XGV-74. Purifies the heavy liquid phase, which is the major part of the feed mixture. The light phase becomes concentrated.

Utilities consumption

Electric power at 40 m ³ /h	36 kW
Operating liquid	0.3 l/discharge plus 10-100 l/h
Flushing liquid per discharge	max. 18 l
Cooling liquid for the lubricating oil	100 l/h

Dimensions

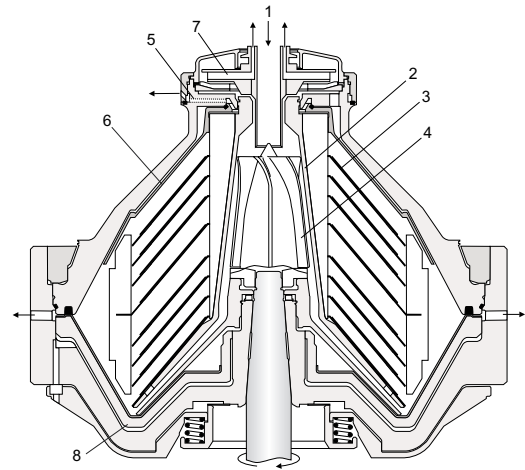
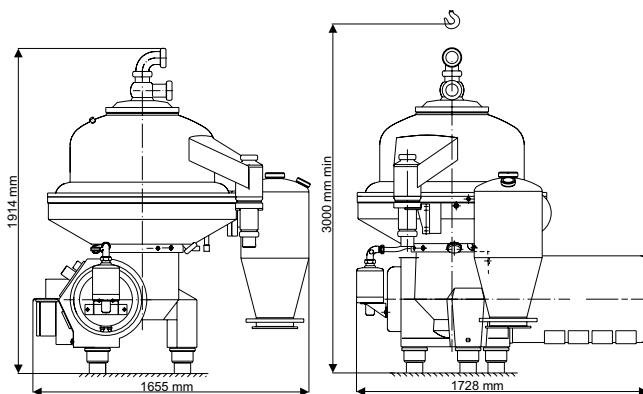

Fig. 2 Typical bowl drawing for a solids-ejecting centrifuge (concentrator model). The details illustrated do not necessarily correspond to the centrifuge described.

Technical specification

Hydraulic capacity	50 m ³ /h
Bowl speed	4480 rpm
Motor speed synchr. 50/60/65 Hz	1500/1800/1950 rpm
Centrifugal force inside bowl	max. 7315 g
Bowl volume	55 l
Sludge space volume	approx. 26 l
Motor power installed 1500/1800 rpm synchr.	45/52 kW
Starting time	10-12 min
Stopping time, at 400 kPa brake pressure	22-25 min
Inlet pressure at 35 m ³ /h	400 kPa
Outlet pressure, oil	0 kPa
Outlet pressure, heavy phase	650 kPa
Sound pressure	83 dB(A) ¹⁾
Overhead hoist lifting capacity	min. 1000 kg

¹⁾ According to EN ISO 4871

Connections

Feed inlet diameter	76 mm (3") SMS Union
Heavy liquid outlet diameter	76 mm (3") SMS Union
Light liquid outlet diameter	76 mm (3") hose connections
Solids outlet	DN 200, PN 10 ¹⁾

¹⁾ In compliance with DIN 2642

Shipping data (approximate)

Centrifuge incl. bowl and motor	2005 kg
Bowl weight	820 kg
Gross weight	2770 kg
Volume	5.6 m ³

How to contact Alfa Laval

Contact details for all countries are continually updated on our website. Please visit www.alfalaval.com to access the information direct.